

Demo system installation manual

Principle of operation

Wire breaks are detected by checking the rotation of the reel. A series of magnets is placed on the brake disc, integral with the reel; a magnetic sensor constantly monitors the transit of the magnets and reacts if this transit does not occur within a specified time period. A coded alarm signal is transmitted to a master control unit.



It is strongly recommended to **read all the instructions** contained in this manual **before carrying out any operation.**

Preliminary controls

The preliminary phase of the installation is to verify the correct receipt of alarm signals.

Place the receiver preferably near the control desk of the stranding machine, connect the power supply, activate the system by putting the system switch in position "1", verify that the LED "ON" on the receiver is turned on.

Place a transmitter near the farthest reel from the receiver.

Short for a brief moment the two wires coming out of the transmitter, wait a few seconds and check the LED on the transmitter; while the LED is alight, the LED on the receiver indicating the number of the transmitter should turn on.

If everything works well, the preliminary phase has been completed.

A909 demo RX installation

Do not place the receiver into a metallic cabinet if an antenna is connected to the back of the enclosure.

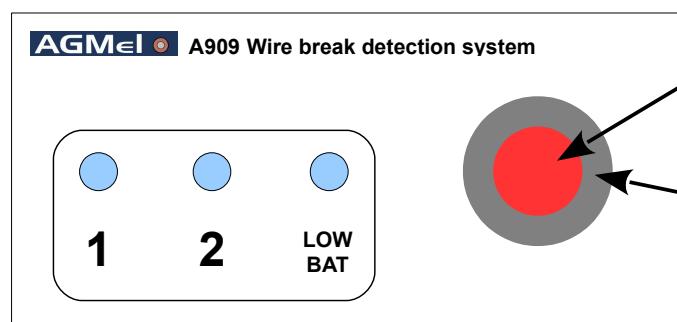

Led is alight when the system is active

System switch
Press to activate

Front

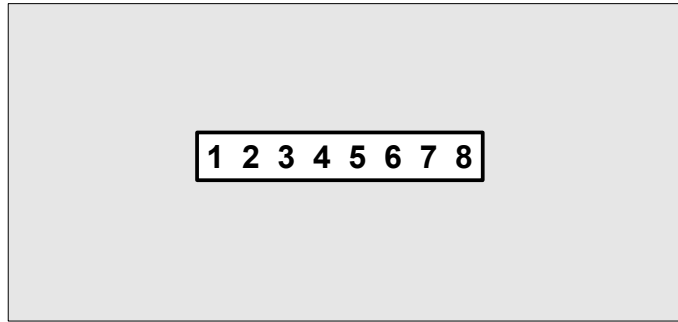

Rear

Rear terminal panel connections

Pin No	Signals	Function
1	+ 12 ÷ 27 Vdc	Power supply
2	GND	Power ground
3	Reset	Remote system on-off
4	SSM	Signal strength monitor
5	GND	Ground
6	N. O.	Relay output
7	C	
8	N. C.	

Simplified wiring diagram

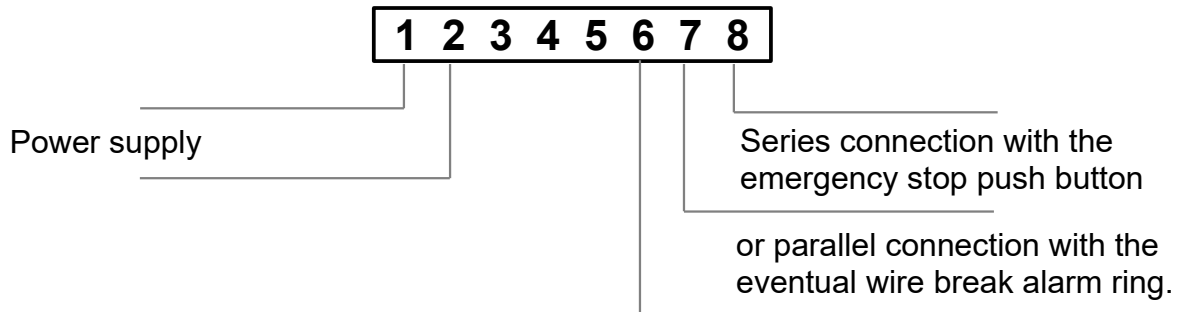

Complete wiring diagram

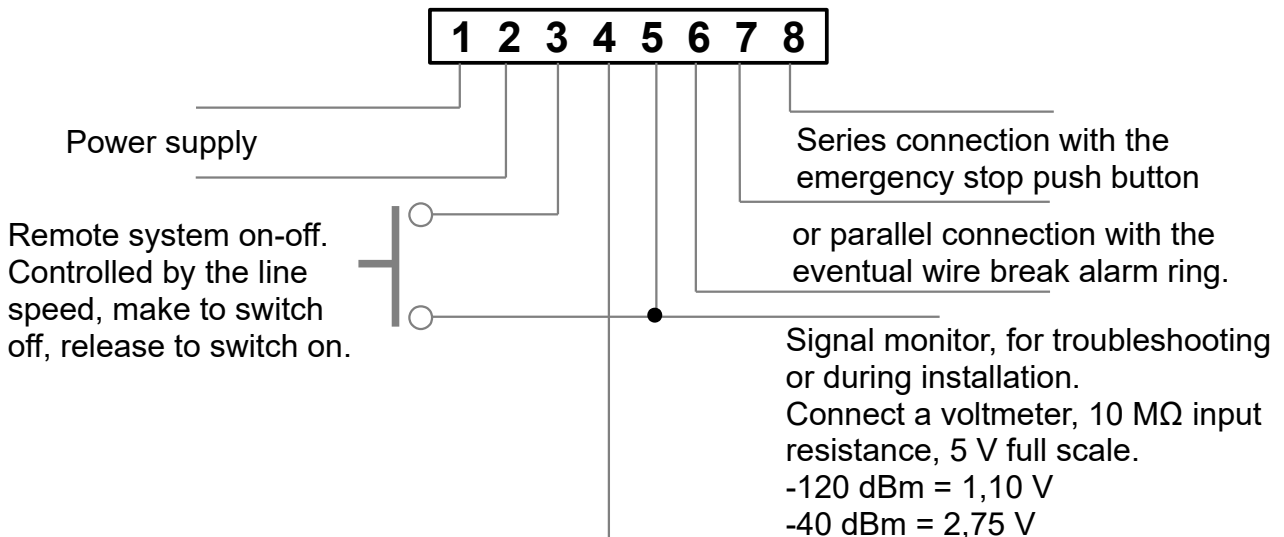

Transmitter configuration

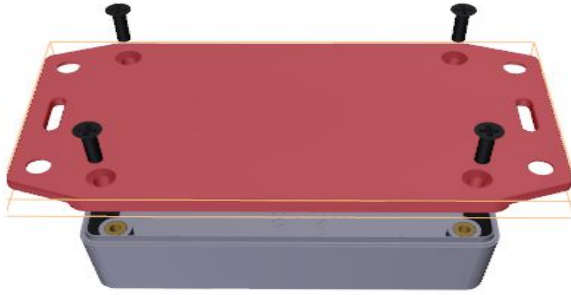

To program the transmitter, remove the four screws on the bottom.

Warning, incorrect programming could affect the proper operation.

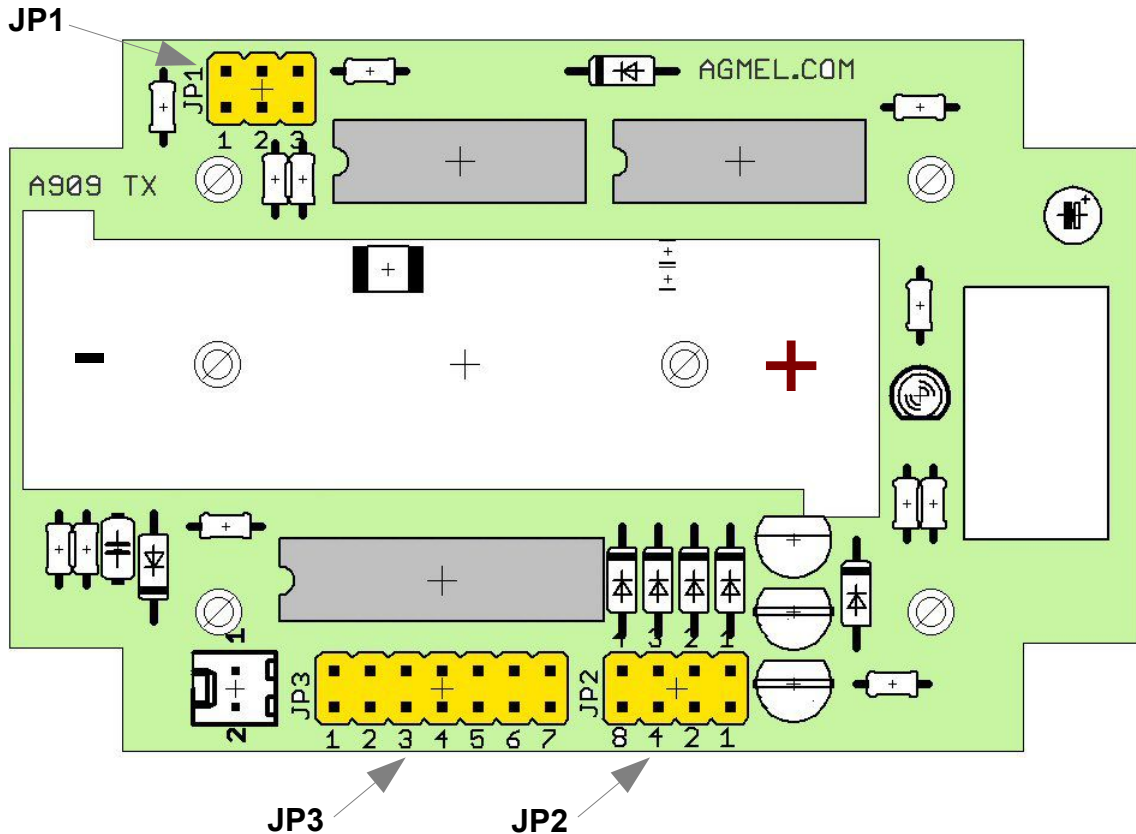

Jumpers settings

- Setting the maximum time delay before sending the alarm
Set the jumpers **JP1**:

= 2,2 s = 4,4 s = 6,6 s = 8,8 s

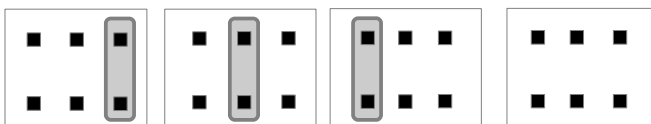

 indicates a shorted position

To overcome the ramp-up speed, the first time interval has a duration of 30% higher than the others, so for example, if jumper 1 position 2 is shorted, after the first pulse, the transmitter waits 5.7 seconds before sending an alarm, then it waits 4.4 seconds.

- Transmitter code number setting
Set the binary coded jumpers **JP2** :

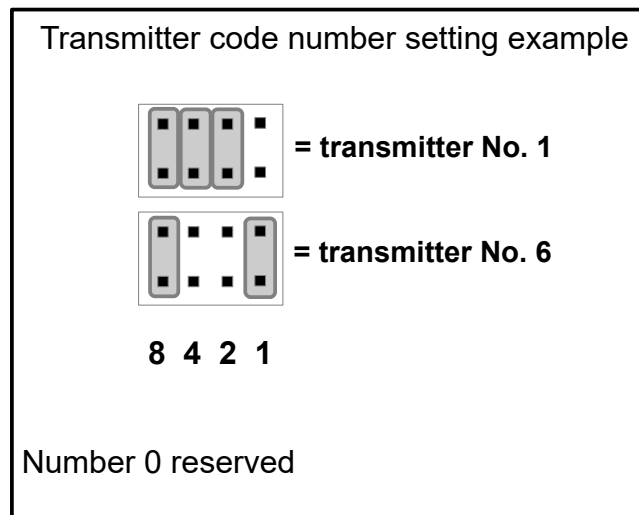

- 3) Serial address setting
Set the jumpers **JP3** so that they match the serial address setting of the receiver.

Sample calculation of maximum time delay before sending the alarm

Reel diameter $d = 560$ mm Minimum line speed $v = 300$ m/h

Maximum time for one turn of the reel = $3,6 \pi d / v = 3,6 * 3,14 * 560 / 300 = 21,1$ s

Time for the calculation must be at least 25 % higher: $21,1 + 25\% * 21,1 = 26,4$ s

Time interval = $26,4 / \text{No. of magnets}$

No. of magnets	time interval [s]	J1 position [s]
3	8,8	8,8
4	6,6	6,6
5	5,3	6,6
6	4,4	4,4
7	3,8	4,4
8	3,3	4,4
9	2,9	4,4

Transmitter installation

Mount the transmitter in a protected place and so that the internal antenna (shown in the figure) is preferably away from metal parts.

You can check the signal strength by connecting a voltmeter to terminals 6 and 7 of the receiver, the higher is the voltage measured during the transmission and the better the quality of signal received.

The transmitter enables a link at distance up to 75 meters in building.

Solder the pair of wires of the transmitter with the wires of the sensor, polarity doesn't matter.

You can install extension wiring so long as it needs.

If conditions permit, the assembly can be simplified by mounting the sensor inside the transmitter.

Mark the desired position and we will send another transmitter amended.

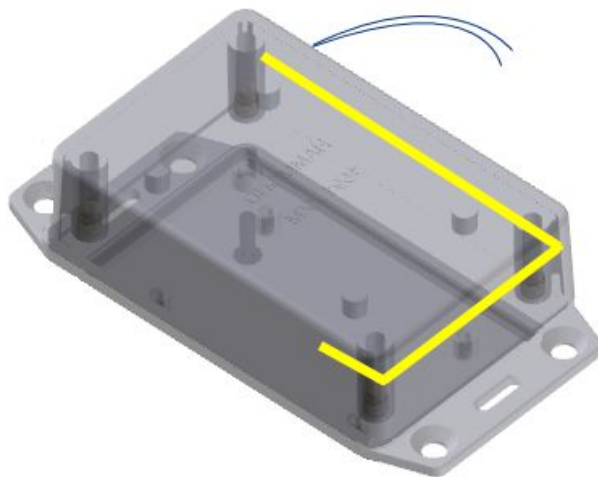

Magnets and sensor installation

The disc magnets supplied are NdFeB, N42 grade, 10 mm diameter x 3 mm thick. Clean carefully the disc where the magnets will be mounted, install the magnets equally spaced and fix them using epoxy glue.

**Do not use hot glue !
The magnets lose their magnetization after 80 °C**

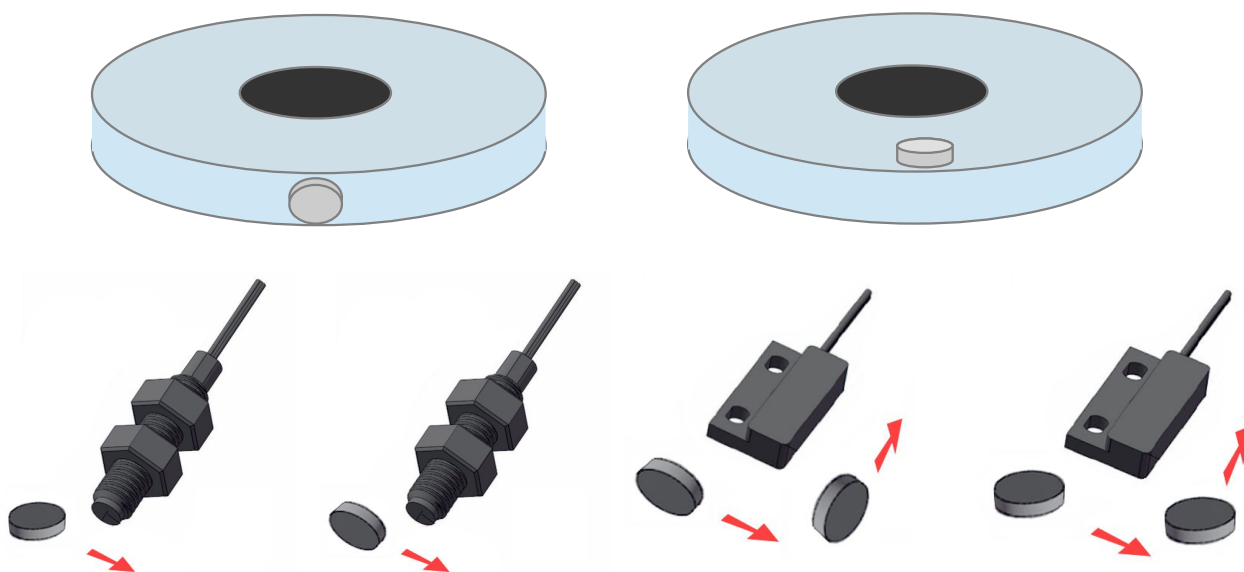

The typical life of the sensors supplied is more than 20 years of continuous operation. Securely mount the sensor and prevent accidental shock.

The positioning of the sensors and the distance between them and the magnets depend on the particular application, there is no general rule.

Adjust the distance of the sensor from the magnets and their mutual position using an ohmmeter connected to the two wires of the sensor: by spinning the disk where the magnets are mounted, the ohmmeter should indicate the effective closure of the sensor to the passage of all the magnets.

Installation example

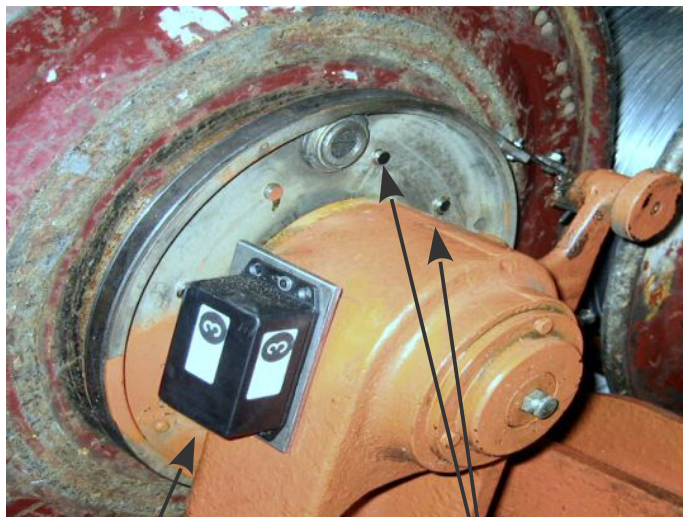

Transmitter with sensor inside

Magnets

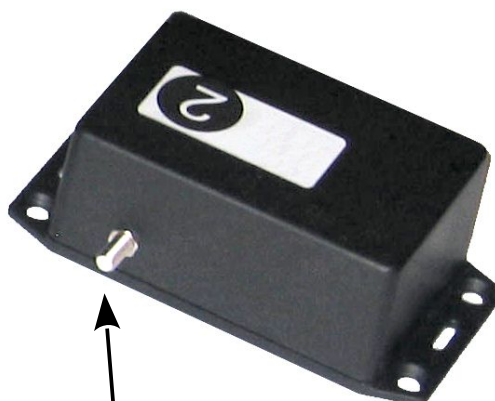

Sensor



Demo Receiver

System operation

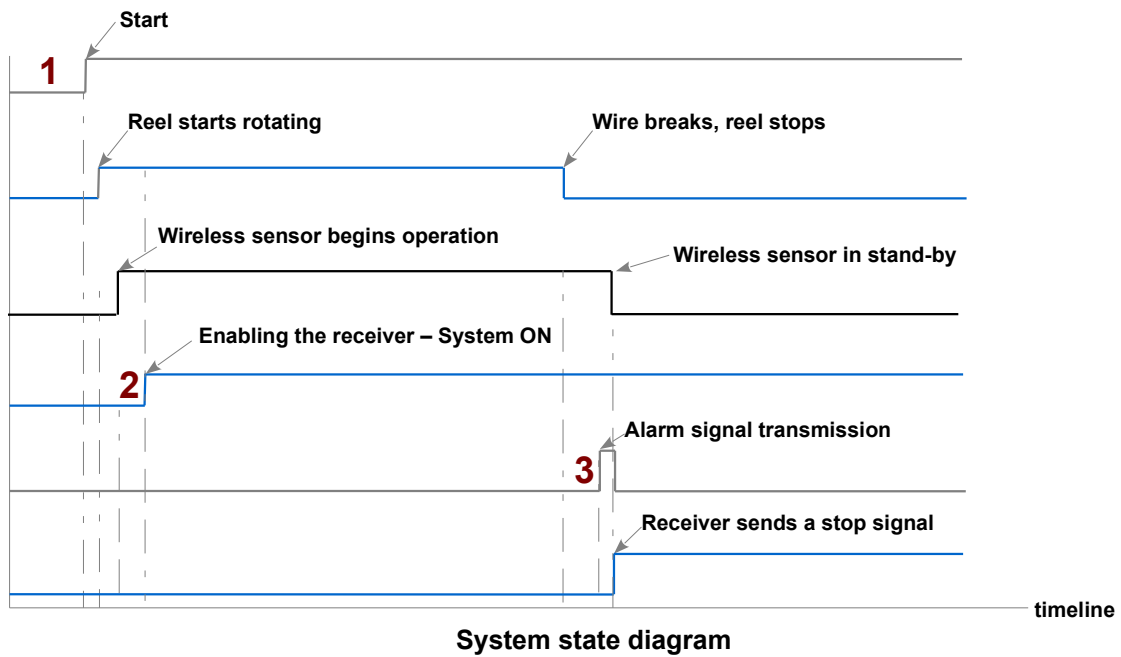

1 The machine starts working.

To reduce operator intervention and setting errors, each transmitter will function automatically after detecting the rotation of the reel, therefore the operator must ensure, during starting of the machine, that the empty reels are properly braked and that the full reels rotate.

2 System ON

The machine has reached the line speed, alarm system is switched on. The wireless sensors are switched on automatically.

3 Alarm signal transmission

The wire breaks, reel stops rotating.

Wireless sensor transmits a coded alarm signal.

Malfunctions of the circuit could result from an insufficient supply voltage.

To prevent this possibility, the battery voltage is monitored and the system transmits a battery low alarm if the battery voltage drops below 3.1 volts.

Under these conditions a warning signal is transmitted instead of the reel number code, because there may not be a second chance to transmit.

Change all the batteries in the transmitters at the same time.

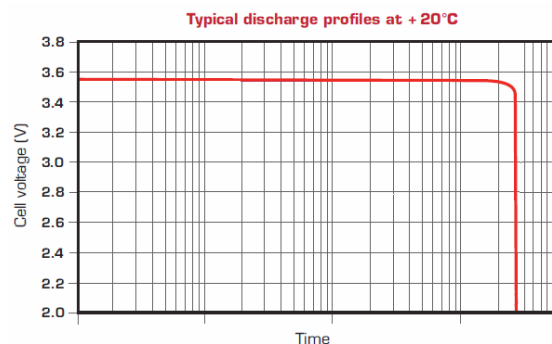

Troubleshooting

If placing the antenna on the back of the receiver results in a weak signal, install the two antennas alongside the machine as illustrated in the image below.

